

LEND LEASE CIRCULAR QUAY

Planning Proposal Acoustic Assessment

October 2015

Lend Lease Development

TG471-01F02 (r6) Planning Proposal Acoustic Assessment

Document Details

Detail	Reference
Doc Reference:	TG471-01F02 (r6) Planning Proposal Acoustic Assessment
Prepared for:	Lend Lease Development
Address:	Level 5, 30 The Bond 30 Hickson Rd Millers Point NSW 2000
Attention:	Warwick Bowyer

Document Control

Date	Revision History	Non-Issued Revision	Issued Revision	Prepared	Instructed	Authorised
24.10.2013	Internal Draft	0		AB	GW	
12.11.2013	Revised Internal Draft	1		AB	GW	GW
14.11.2013	Issued Draft		2	AB	GW	GW
21.11.2013	Revised Draft		3	GW	-	GW
22.11.2013	Final		4	GW	-	GW
10.06.2014	Revised Final		5	AC	GW	GW
13.10.2015	Increased height		6	GW	-	GW

The work presented in this document was carried out in accordance with the Renzo Tonin & Associates Quality Assurance System, which is based on Australian Standard / NZS ISO 9001.

This document is issued subject to review and authorisation by the Team Leader noted by the initials printed in the last column above. If no initials appear, this document shall be considered as preliminary or draft only and no reliance shall be placed upon it other than for information to be verified later.

This document is prepared for our Client's particular requirements which are based on a specific brief with limitations as agreed to with the Client. It is not intended for and should not be relied upon by a third party and no responsibility is undertaken to any third party without prior consent provided by Renzo Tonin & Associates. The information herein should not be reproduced, presented or reviewed except in full. Prior to passing on to a third party, the Client is to fully inform the third party of the specific brief and limitations associated with the commission.

The information contained herein is for the purpose of acoustics only. No claims are made and no liability is accepted in respect of design and construction issues falling outside of the specialist field of acoustics engineering including and not limited to structural integrity, fire rating, architectural buildability and fit-for-purpose, waterproofing and the like. Supplementary professional advice should be sought in respect of these issues.

Contents

1	Introduction	5
2	Project Description	6
2.1	Overview of Proposed Development	6
2.2	Surrounding Land Uses	8
2.3	Acoustic Considerations	9
3	Existing Acoustic Environment	10
4	Construction Noise and Vibration	14
4.1	Airborne Construction Noise Objectives	14
4.1.1	DECC Interim Construction Noise Guideline (ICNG)	14
4.1.2	City of Sydney Construction Noise Code	15
4.1.3	Project Construction Noise Goals	16
4.2	Construction Vibration Objectives	17
4.2.1	Disturbance to Buildings Occupants	17
4.2.2	Structural Damage to Buildings	19
4.2.2.1	British Standard	19
4.2.2.2	German Standard	19
4.3	Construction Noise & Vibration Assessment	20
4.3.1	Demolition, Excavation & Construction Program and Equipment	20
4.3.2	Noise Assessment	21
4.3.3	Vibration Assessment	22
4.3.3.1	Vibration Sensitive Receivers	22
4.3.3.2	Indicative Minimum Working Distances for Vibration Intensive Equipment	23
4.3.3.3	Potential for Vibration Impacts on Sensitive Items	24
4.4	Construction Noise & Vibration Management	24
5	Operational Noise	27
5.1	Noise Criteria	27
5.2	Review and Recommendations	28
6	Noise and Vibration Intrusion	30
6.1	General Noise Intrusion Criteria	30
6.2	Rail Noise and Vibration Criteria	31
6.3	Review and Recommendations	32
6.3.1	Ambient Noise Intrusion	32
6.3.2	CBD Rail Link (CBDRL)	32
7	Conclusion	34
APPENDIX A	Glossary of Terminology	35

List of Tables

Table 1:	Nearest Receiver Locations	8
Table 2:	Measurement Locations	10
Table 3:	Short-Term Noise Measurement Results	12
Table 4:	Long-Term Noise Measurement Results - Location L9 Roof Top of 4 Dalley Street	13
Table 5:	Noise Management Levels at Residential Receivers	14
Table 6:	Noise Management Levels at Other Noise Sensitive Land Uses	15
Table 7:	Summary of City of Sydney Noise Criteria	15
Table 8:	Construction Noise Goals within Standard Hours	16
Table 9:	Types of Vibration	17
Table 10:	Preferred and Maximum Levels for Human Comfort	18
Table 11:	BS 7385 Cosmetic Structural Damage Criteria	19
Table 12:	DIN 4150-3 Structural Damage Criteria	20
Table 13:	Demolition, Excavation and Construction Equipment & Sound Power Levels, dB(A)	20
Table 14:	Predicted Demolition Noise Levels At Nearest Affected Receivers	21
Table 15:	Nearest Vibration Receivers	22
Table 16:	Recommended Minimum Working Distances for Vibration Intensive Equipment	23
Table 17:	Construction Noise and Vibration Management Options	24
Table 18:	Measured L ₉₀ Background Noise Levels	27
Table 19:	Recommended Design Sound Levels for Different Areas of Occupancy in Buildings	30
Table 20:	Short-Term Noise Measurement Results for Noise Intrusion Assessment	32

List of Figures

Figure 1:	Development Site	7
Figure 2:	Site Location, Assessment Locations & Monitoring Locations	11
Figure 3:	Orthogonal Axes for Human Exposure to Vibration	18

1 Introduction

Renzo Tonin & Associates was engaged to prepare an assessment of noise and vibration in relation to the Planning Proposal (PP) submission to be lodged with the City of Sydney for the Lend Lease Circular Quay (LLCQ) project. The PP submission will ultimately facilitate the lodgement of a development application (DA) for the LLCQ scheme.

This report specifically addresses the matters pertaining to noise and vibration emission during the demolition, excavation, construction and operation of the site. .

At this PP stage, there is insufficient detail to carry out a detailed acoustic assessment of the proposed development; however, this report outlines the acoustic consideration for the development, including:

- Relevant noise and vibration criteria applicable to the development
- Identification of noise and vibration sensitive development surrounding the site
- Existing ambient and background noise levels at sensitive receptor locations
- Establishment of project noise goals
- Potential noise and vibration impacts from construction and operation of the development
- Potential noise impacts from the existing or future environment on the development
- Methods by which noise and vibration can be managed and mitigated in accordance with the relevant policies and guidelines

The work documented in this report was carried out in accordance with the Renzo Tonin & Associates Quality Assurance System, which is based on Australian Standard / NZS ISO 9001. Appendix A contains a glossary of acoustic terms used in this report.

2 Project Description

2.1 Overview of Proposed Development

The proposal is for the construction of a commercial office tower up to 248m high at the site of 174-182 George Street and 33-35 Pitt Street, Sydney. Prior to construction of the commercial office tower, demolition is required of the existing commercial office buildings located at 182 George Street and 33-35 Pitt Street.

Additionally, it is proposed to retain, modify and adaptively reuse 'Jacksons on George' and to develop a parcel of land located at 182 George Street into a new public square and interconnecting laneway. Furthermore, it is proposed to incorporate Crane Lane into the development site. 'The Rugby Club' located at 31A Pitt Street has been identified as an optional site which may potentially be included in the site. However, this has not been finalised at this point in time.

The Proposed Development will involve the creation of a major new public plaza together with a network of integrated laneways. The plaza will have physical and visual access from the surrounding streets and laneways and both will be activated up to 24 hours, 7 days by a diverse range of surrounding and neighbouring existing and proposed land uses including Hotel, Club, Retail, Commercial Office and Residential.

The land parcels covered by the planning proposal are set out below (see also Figure 1):

Informal title	Address	Lot and DP
The Pitt Street property	33-35 Pitt Street	Lot 7 DP 629694
The George Street Property	182 George Street	Lot 182 DP 606865
Jacksons on George	174-176A George Street	Lot 181 DP 606865
Mirvac Triangle	Part of 200 George Street development site	Lot 1 in DP 69466 and Lot 4 in DP 57434 The part of the above Lots to which the PP relates is referred to as Lot 2 in the draft plan of subdivision Nov 13, 2012 (Issue 7) contained in the executed VPA between the City of Sydney and Mirvac
Crane Lane including walkway (aerial bridge)	Crane Lane extending east from George St, then north to Rugby Place	Lot 1 and 2 in DP 880891. Lot 1 is in stratum above Lot 2.
Rugby Club (Optional Site)	Rugby Place	Lot 180 DP 606866

Figure 1: Development Site



2.2 Surrounding Land Uses

The site is largely surrounded by other commercial office buildings, with the nearest residences located to the east across George Street and to the west across Pitt Street.

Note is made that a new commercial building is currently under construction at 190-200 George Street DA 2012/893. A completion date at this stage is forecast early 2016, and it is expected that the building will be occupied by Ernst and Young prior to the commencement of demolition, excavation or construction of LLCQ. The site will be considered accordingly for the assessment of the noise and vibration emission from the proposal.

In addition, the City of Sydney has recently granted consent for two neighbouring residential developments at 1 Alfred Street DA 2010/2029 and 19 Pitt Street (Stage 1 consent only) DA 2010/1533. These future residential sites will be considered for the assessment of the noise and vibration emission from the proposal.

The nearest receptor locations potentially relevant to the assessment of noise and vibration emission from the site are presented in Table 1. The location of the nearest residential and commercial premises are shown in Figure 2 on page 11.

Table 1: Nearest Receiver Locations

Location ID	Receiver Description
Residential/Hotel Receivers	
R1	Four Seasons Hotel
R2	Quay West
R3	Marriott Hotel
R4	1 Alfred Street DA 2010/2029
R5	19 Pitt Street (Stage 1 consent only) DA 2010/1533
Commercial Receivers	
C1	31A Pitt Street
C2	19-31 Pitt Street
C3	1 Alfred Street
C4	22 Pitt Street
C5	Gateway, 1 Macquarie Place
C6	37 Pitt Street
C7	6 Dalley Street
C8	210 George Street
C9	Grosvenor Place, 225 George Street
C10	200 George Street (incomplete)

2.3 Acoustic Considerations

The following sets out the primary acoustic consideration for the project along with the sections of this report in which they are discussed.

Acoustic Consideration	Report Section
Demolition, excavation and construction noise and vibration	Chapter 4
Operational noise and vibration emission	Chapter 5
Ambient noise and vibration intrusion to proposed development	Chapter 6

3 Existing Acoustic Environment

The criteria used to assess construction and operation noise impacts upon nearby sensitive receiver locations are generally established from the existing acoustic environment of the area. Existing ambient noise levels can also be used for the assessment of ambient noise intrusion.

Appendix B of the NSW '*Industrial Noise Policy*' ('INP') presents two methods of determining the existing noise levels of an area being '*B1 – Long-term background noise method*' and '*B2 – Short-term background noise method*'. For this project both long-term and short-term noise monitoring were used.

Noise level measurements were conducted in April 2012 and October 2013. The measurement locations are detailed in Table 2 and shown in Figure 2.

Table 2: Measurement Locations

Location ID	Address	Description
Short-term Noise Monitoring		
S1	Level 4, 182 George Street	Internal occupied office, south western area of the building.
S2	Level 8, 182 George Street	Internal occupied office, south eastern area of the building.
S3	Level 5, 6 Dalley Street	Internal unoccupied location. Computers and equipment only.
S4	Cnr Essex Street and Gloucester Street	SLM at 1.5m above the ground level of the footpath.
S5	Cnr Harrington Street and Gloucester Street	SLM at 1.5m above the ground level of the footpath.
S6	2 Bulletin Place	SLM at 1.5m above the ground level of the footpath.
S7	30 Pitt Street	SLM at 1.5m above the ground level of the footpath.
S8	37 Pitt Street	SLM at 1.5m above the ground level of the footpath.
Long-term Noise Monitoring		
L9	4 Dalley Street	Noise logger at 1.5m above the roof level.

Noise level measurements were conducted in general accordance with AS1055.1-1997. Statistical noise levels were acquired in both overall and octave band frequencies using a Brüel & Kjær Type 2250 precision sound level meter. This instrument complies with AS IEC 61672.1 2004 '*Electroacoustics – Sound Level Meters*' and is designated as a Type 1 instrument having an accuracy suitable for field and laboratory use. The calibration of the meter was checked in the field immediately before and after the noise measurements using a Brüel & Kjær Type 4231 calibrator and no drift in calibration was observed.

A summary of the long-term and short-term measurement results are presented in Table 3 and Table 4.

Figure 2: Site Location, Assessment Locations & Monitoring Locations

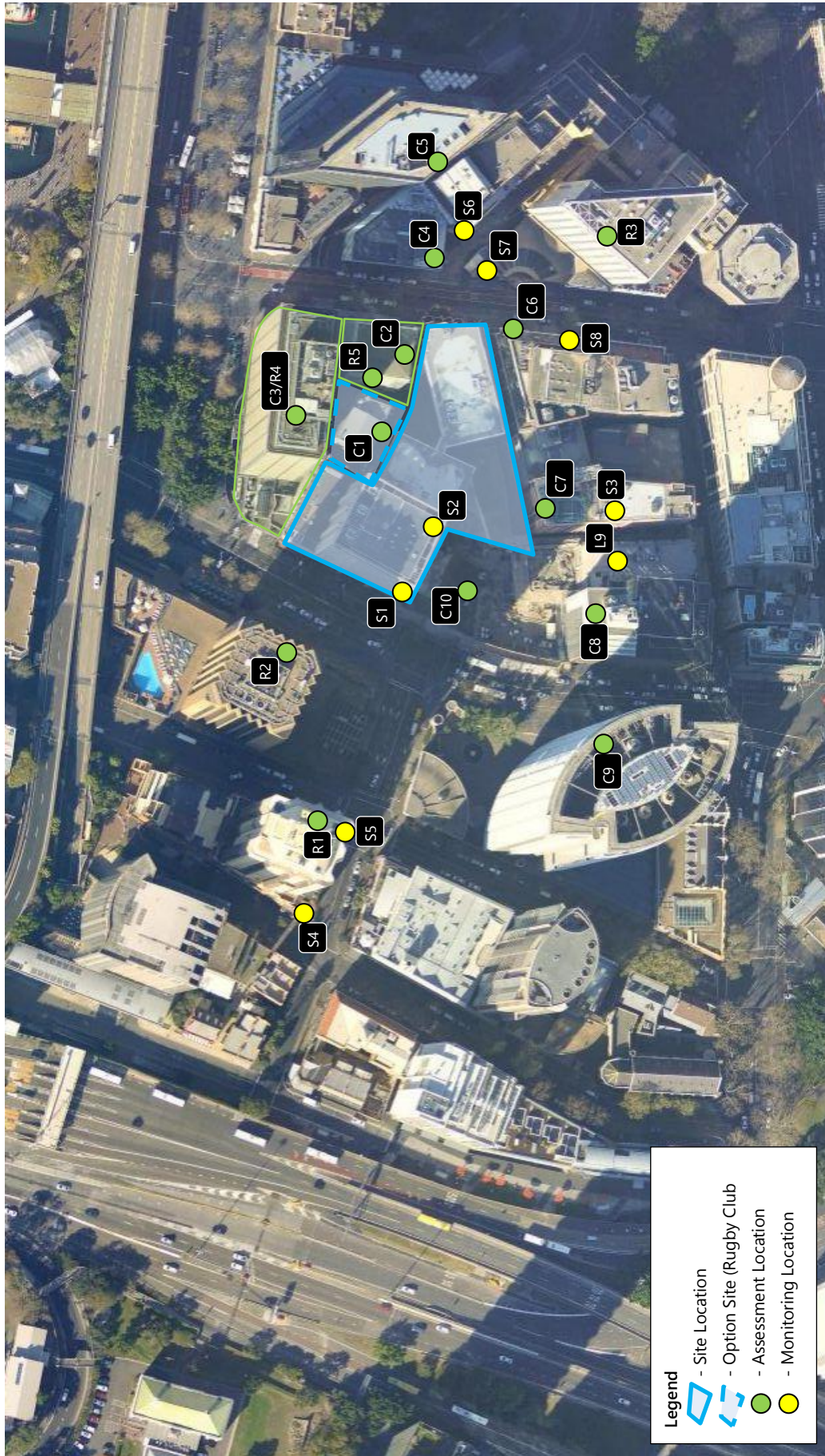

Table 3: Short-Term Noise Measurement Results

Date / Time	Descriptor	Overall dB(A)	Octave Band Centre Frequency – Hz (dBZ)								
			31.5	63	125	250	500	1k	2k	4k	8k
Location S1 - Level 4, 182 George St (internal)											
Friday 13/4/2012	L _{eq}	49	62	55	52	48	49	41	39	34	27
09:52-10:07	L ₉₀	41	59	52	49	43	37	31	28	24	18
Location S2 - Level 8, 182 George St (internal)											
Friday 13/4/2012	L _{eq}	47	55	52	51	46	46	42	36	28	20
10:11-10:26	L ₉₀	38	52	48	48	43	34	28	22	16	13
Location S3 – Level 5, 6 Dalley St (internal)											
Friday 13/4/2012	L _{eq}	64	58	53	56	61	62	60	56	50	39
09:12-09:27	L ₉₀	64	54	51	54	60	61	59	55	49	38
Location S4 - Cnr of Essex St and Gloucester St (external)											
Friday 13/4/2012	L _{eq}	66	73	74	69	64	63	62	58	52	47
10:31-10:46	L ₉₀	64	69	69	64	62	61	60	55	47	35
Saturday 14/4/2012	L _{eq}	69	74	81	71	68	65	64	60	56	48
10:50-11:05	L ₉₀	62	68	67	62	61	59	58	54	46	34
Location S5 - Cnr of Harrington St and Gloucester St (external)											
Friday 13/4/2012	L _{eq}	69	76	75	70	67	66	64	61	55	48
10:47-11:02	L ₉₀	64	71	69	64	63	61	60	55	48	38
Location S6 - 2 Bulletin Place (external - front entrance)											
Friday 13/4/2012	L _{eq}	67	73	72	69	66	64	62	59	58	49
11:08-11:23	L ₉₀	63	70	67	64	62	61	59	54	48	37
Friday 18/10/2013	L _{eq}	66	73	74	68	65	64	62	57	51	44
14:20-14:35	L ₉₀	63	70	66	65	63	61	59	53	46	35
Saturday 19/10/2013	L _{eq}	64	71	72	67	64	62	60	55	49	41
8:35-8:50	L ₉₀	62	67	64	64	62	59	57	52	45	31
Location S7 - 30 Pitt Street (external - in front of the outdoor cafe)											
Friday 13/4/2012	L _{eq}	67	75	77	68	66	65	62	58	52	46
11:24-11:39	L ₉₀	63	71	68	64	63	61	58	54	46	35
Saturday 14/4/2012	L _{eq}	71	74	79	69	65	65	67	65	53	46
11:12-11:27	L ₉₀	62	69	67	64	61	59	57	52	44	32
Location S8 - 37 Pitt St (external)											
Friday 18/10/2013	L _{eq}	68	73	74	70	67	66	64	60	54	46
14:38-14:48	L ₉₀	63	70	67	66	62	61	58	53	46	35
Saturday 19/10/2013	L _{eq}	66	71	72	67	63	62	61	59	51	42
8:18-8:33	L ₉₀	60	67	63	62	60	57	55	51	44	33
Saturday 19/10/2013	L _{eq}	66	73	72	67	64	62	61	58	51	42
8:51-9:06	L ₉₀	61	68	65	63	60	58	56	52	45	32

Table 4: Long-Term Noise Measurement Results - Location L9 Roof Top of 4 Dalley Street

Period	Descriptor	Overall dB(A)	Octave Band Centre Frequency – Hz (dBZ)								
			31.5	63	125	250	500	1k	2k	4k	8k
Monday 29/10/2012 - Monday 5/11/2012											
Day 7:00am - 6:00pm	L _{eq}	61	69	67	65	62	59	56	52	45	34
	L ₉₀	60	64	64	63	61	58	55	50	43	32
Evening 6:00pm - 10:00pm	L _{eq}	59	69	66	63	60	57	54	50	43	33
	L ₉₀	57	62	61	59	56	54	52	47	41	31
Night 10:00pm - 7:00am	L _{eq}	57	65	64	61	58	55	52	48	43	32
	L ₉₀	55	60	60	58	56	52	49	46	41	31

4 Construction Noise and Vibration

4.1 Airborne Construction Noise Objectives

4.1.1 DECC Interim Construction Noise Guideline (ICNG)

Construction noise management levels can be determined using the NSW *Interim Construction Noise Guideline* (ICNG, DECC 2009). Table 5 (reproduced from Table 2 of the ICNG) and Table 6 set out the noise management levels for various noise-sensitive land use developments, including residential and commercial premises.

Table 5: Noise Management Levels at Residential Receivers

Time of Day	Management Level L_{Aeq} (15 min)	How to Apply
Recommended standard hours: Monday to Friday 7 am to 6 pm Saturday 8 am to 1 pm No work on Sundays or public holidays	Noise affected RBL + 10dB(A)	The noise affected level represents the point above which there may be some community reaction to noise. Where the predicted or measured L_{Aeq} (15 min) is greater than the noise affected level, the proponent should apply all feasible and reasonable work practices to meet the noise affected level. The proponent should also inform all potentially impacted residents of the nature of works to be carried out, the expected noise levels and duration, as well as contact details.
	Highly noise affected 75dB(A)	The highly noise affected level represents the point above which there may be strong community reaction to noise. Where noise is above this level, the relevant authority (consent, determining or regulatory) may require respite periods by restricting the hours that the very noisy activities can occur, taking into account: times identified by the community when they are less sensitive to noise (such as before and after school for works near schools, or mid-morning or mid-afternoon for works near residences if the community is prepared to accept a longer period of construction in exchange for restrictions on construction times.
Outside recommended standard hours	Noise affected RBL + 5dB(A)	A strong justification would typically be required for works outside the recommended standard hours. The proponent should apply all feasible and reasonable work practices to meet the noise affected level. Where all feasible and reasonable practices have been applied and noise is more than 5dB(A) above the noise affected level, the proponent should negotiate with the community. For guidance on negotiating agreements see section 7.2.2 of the ICNG.

Table 6: Noise Management Levels at Other Noise Sensitive Land Uses

Land use	Where Objective Applies	Management level
		L_{Aeq} (15 min)
Classrooms at schools and other educational institutions	Internal noise level	45 dB(A)
Hospital wards and operating theatres	Internal noise level	45 dB(A)
Places of worship	Internal noise level	45 dB(A)
Active recreation areas	External noise level	65 dB(A)
Passive recreation areas	External noise level	60 dB(A)
Community centres	Depends on the intended use of the centre.	Refer to the 'maximum' internal levels in AS2107 for specific uses.
Commercial premises	External noise level	70 dB(A)
Industrial premises	External noise level	75 dB(A)

Notes: Noise management levels apply when receiver areas are in use only.

At residential receivers, a noise objective of $RBL + 10dB(A)$ shall apply. At all other noise sensitive receivers, a noise objective of $L_{Aeq(15minute)} 70dB(A)$ shall apply. Construction activity noise above this level should be handled as described in Table 5 above.

4.1.2 City of Sydney Construction Noise Code

The City of Sydney also has its own Construction Noise Code which sets out noise goals specific to development in the Central Business District. The standard time periods, noise targets and noise descriptors differ from the ICNG, and are summarised in Table 7.

Table 7: Summary of City of Sydney Noise Criteria

Category	Time Period	Permissible Noise Level [dB(A)] $L_{A av max}$ (15 minute)
Mondays To Fridays		
4	00:00 to 07:00	Background + 0
1	07:00 to 08:00	Background + 5
1	08:00 to 19:00	Background + 5 + 5 to be determined on a site basis
2	19:00 to 23:00	Background + 3
4	23:00 to 24:00	Background + 0
Saturdays		
4	00:00 to 07:00	Background + 0
1	07:00 to 08:00	Background + 5
1	08:00 to 17:00	Background + 5 + 5 to be determined on a site basis
2	17:00 to 23:00	Background + 3
4	23:00 to 24:00	Background + 0
Sundays & Public Holidays		
4	00:00 to 07:00	Background + 0
3	07:00 to 17:00	Background + 3
4	17:00 to 24:00	Background + 0

Whilst time periods and noise descriptors differ slightly between the City of Sydney Code and ICNG, the primary difference is that the ICNG acknowledges the challenges of reducing noise emission from construction works and does not set strict permissible noise level. The ICNG requires the application of all feasible and reasonable measures where the 'noise affected' targets are breached rather than consideration that work should cease. Consideration of more stringent controls or restrictions of site operations are required where noise levels exceed the ICNG 'highly affected' noise targets. It is noted that the ICNG supersedes previous EPA noise criteria framed as noise limits rather than targets/objectives.

The approach of the ICNG is considered more practical and reasonable for the management of construction noise. The construction time periods outlined in the City of Sydney Code should however be adopted for the site.

4.1.3 Project Construction Noise Goals

The lowest measured background noise levels have been used to establish the noise affected target for residential receivers in accordance with the INP procedures for short-term noise monitoring.

To set internal noise targets for commercial offices, guidance has been taken from other internal ICNG targets (which refers to the maximum levels in AS2107:2000) and City of Sydney Code which discusses levels between background +5dB(A) and background +10dB(A). Measurements inside the general office usage of 182 George St reveal levels in the order of 40dB(A), being consistent with the 'satisfactory' internal noise levels prescribed by AS2107:2000 for general office areas. Measurements inside 6 Dalley St revealed higher noise levels as a result of the telephone exchange computer equipment. On this basis an internal goal of 50dB(A) has been set for general commercial offices and criteria of 69dB(A) for 6 Daley St.

Table 8: Construction Noise Goals within Standard Hours

ID	Address	Noise Affected Target L _{Aeq 15minute} dB(A)
Residential Receivers		
R1	Four Seasons Hotel	70 external
R2	Quay West	70 external
R3	Marriott Hotel	70 external
R4	1 Alfred St (applicable only if residential development complete)	70
R5	19 Pitt St (applicable only if residential development complete)	70
Other Noise Sensitive Receivers		
C4 - C9 & C11 - C14	All Commercial Offices	70 external / 50 internal
C10	6 Dalley Street	70 external / 69 internal

4.2 Construction Vibration Objectives

4.2.1 Disturbance to Buildings Occupants

Assessment of potential disturbance from vibration on human occupants of buildings is made in accordance with the DECC's '*Assessing Vibration; a technical guideline*'. The guideline provides criteria which are based on the British Standard BS 6472-1992, '*Evaluation of human exposure to vibration in buildings (1-80Hz)*'. Sources of vibration are defined as either 'Continuous', 'Impulsive' or 'Intermittent'. Table 9 provides definitions and examples of each type of vibration.

Table 9: Types of Vibration

Type of Vibration	Definition	Examples
Continuous vibration	Continues uninterrupted for a defined period (usually throughout the day-time and/or night-time)	Machinery, steady road traffic, continuous construction activity (such as tunnel boring machinery).
Impulsive vibration	A rapid build-up to a peak followed by a damped decay that may or may not involve several cycles of vibration (depending on frequency and damping). It can also consist of a sudden application of several cycles at approximately the same amplitude, providing that the duration is short, typically less than 2 seconds	Infrequent: Activities that create up to 3 distinct vibration events in an assessment period, e.g. occasional dropping of heavy equipment, occasional loading and unloading.
Intermittent vibration	Can be defined as interrupted periods of continuous or repeated periods of impulsive vibration that varies significantly in magnitude	Trains, nearby intermittent construction activity, passing heavy vehicles, forging machines, impact pile driving, jack hammers. Where the number of vibration events in an assessment period is three or fewer, this would be assessed against impulsive vibration criteria.

Source: *Assessing Vibration; a technical guideline*, Department of Environment & Climate Change, 2006

The vibration criteria are defined as a single weighted root mean square (rms) acceleration source level in each orthogonal axis. Section 2.3 of the guideline states:

'Evidence from research suggests that there are summation effects for vibrations at different frequencies. Therefore, for evaluation of vibration in relation to annoyance and comfort, overall weighted rms acceleration values of the vibration in each orthogonal axis are preferred (BS 6472).'

When applying the criteria, it is important to note that the three directional axes are referenced to the human body, i.e. x-axis (back to chest), y-axis (right side to left side) or z-axis (foot to head). Vibration may enter the body along different orthogonal axes and affect it in different ways. Therefore, application of the criteria requires consideration of the position of the people being assessed, as illustrated in Figure 3. For example, vibration measured in the horizontal plane is compared with x- and y-axis criteria if the concern is for people in an upright position, or with the y- and z- axis criteria if the concern is for people in the lateral position.

Figure 3: Orthogonal Axes for Human Exposure to Vibration

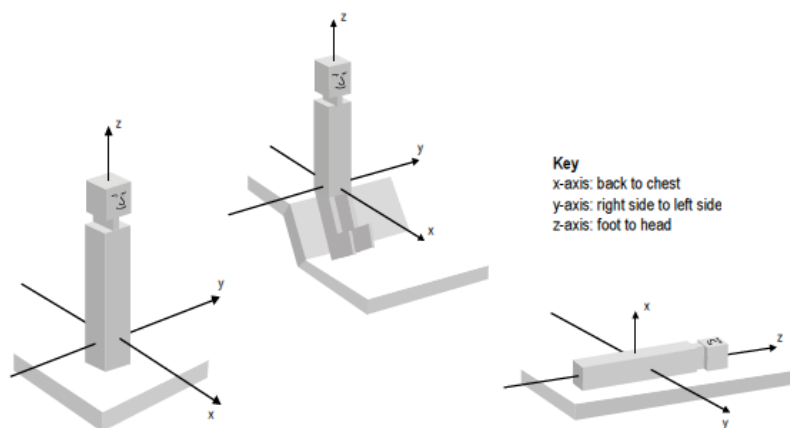

The preferred and maximum values for continuous and impulsive vibration are defined in Table 2.2 of the guideline and are reproduced in Table 10.

Table 10: Preferred and Maximum Levels for Human Comfort

Location	Assessment period ⁽¹⁾	Preferred values		Maximum values	
		z-axis	x- and y-axis	z-axis	x- and y-axis
Continuous vibration ⁽³⁾ (Weighted RMS Acceleration, m/s², 1-80Hz)					
Critical areas ⁽²⁾	Day or night time	0.005	0.0036	0.010	0.0072
Residences	Daytime	0.010	0.0071	0.020	0.014
	Night time	0.007	0.005	0.014	0.010
Offices, schools, educational institutions and places of worship	Day- or night time	0.020	0.014	0.040	0.028
Workshops	Day- or nighttime	0.04	0.029	0.080	0.058
Impulsive vibration ⁽³⁾ (Weighted RMS Acceleration, m/s², 1-80Hz)					
Critical areas ⁽²⁾	Day or night-time	0.005	0.0036	0.010	0.0072
Residences	Daytime	0.30	0.21	0.60	0.42
	Night-time	0.10	0.071	0.20	0.14
Offices, schools, educational institutions and places of worship	Day- or night-time	0.64	0.46	1.28	0.92
Workshops	Day or night-time	0.64	0.46	1.28	0.92
Intermittent vibration ⁽⁴⁾ (Vibration Dose Values, VDV, m/s^{1.75}, 1-80Hz)					
Critical areas ²	Day or night-time	0.10		0.20	
Residences	Daytime	0.20		0.40	
	Night-time	0.13		0.26	
Offices, schools, educational institutions and places of worship	Day- or night-time	0.40		1.60	
Workshops	Day or night-time	0.80		1.60	

- Notes:
1. Daytime is 7:00am to 10:00pm and night-time is 10:00pm to 7:00am
 2. Examples include hospital operating theatres and precision laboratories where sensitive operations are occurring. There may be cases where sensitive equipment or delicate tasks require more stringent criteria than the human comfort criteria specify above. Stipulation of such criteria is outside the scope of their policy and other guidance documents (e.g. relevant standards) should be referred to. Source: BS 6472-1992

4.2.2 Structural Damage to Buildings

Currently there is no Australian Standard for assessment of vibration induced structural damage. Therefore, reference is made to relevant British and German Standards.

4.2.2.1 British Standard

British Standard 7385: Part 2 '*Evaluation and measurement of vibration in buildings*', can be used as a guide to assess the likelihood of building damage from ground vibration. BS7385 suggests levels at which 'cosmetic', 'minor' and 'major' categories of damage might occur.

BS7385 is based on peak particle velocity and specifies damage criteria for frequencies within the range 4Hz to 250Hz, being the range usually encountered in buildings. At frequencies below 4Hz, a maximum displacement value is recommended. Table 11 sets out the BS7385 criteria for cosmetic damage.

Table 11: BS 7385 Cosmetic Structural Damage Criteria

Group	Type of Structure	Peak component particle velocity, mm/s		
		4Hz to 15Hz	15Hz to 40Hz	40Hz and above
1	Reinforced or framed structures Industrial and heavy commercial buildings	50		
2	Un-reinforced or light framed structures Residential or light commercial type buildings	15 to 20	20 to 50	50

The values set in the Standard relate to transient vibrations and to low-rise buildings. Continuous vibration can give rise to dynamic magnifications due to resonances and may need to be reduced by up to 50%.

The levels set by BS 7385 are considered 'safe limits' up to which no damage due to vibration effects has been observed for certain particular building types. Damage comprises minor non-structural effects such as hairline cracks on drywall surfaces, hairline cracks in mortar joints and cement render, enlargement of existing cracks and separation of partitions or intermediate walls from load bearing walls. 'Minor' damage is considered possible at vibration magnitudes which are twice those given and 'major' damage to a building structure may occur at levels greater than four times those values.

4.2.2.2 German Standard

German Standard DIN 4150 - Part 3 '*Structural vibration in buildings - Effects on Structure*' (DIN 4150-3), also provides recommended maximum levels of vibration that reduce the likelihood of building damage caused by vibration and are generally recognised to be conservative.

DIN 4150-3 presents the recommended maximum limits over a range of frequencies (Hz), measured in any direction, and at the foundation or in the plane of the uppermost floor of a building or structure. The vibration limits increase as the frequency content of the vibration increases. The criteria are presented in Table 12.

Table 12: DIN 4150-3 Structural Damage Criteria

Group	Type of Structure	Vibration Velocity, mm/s			
		At Foundation at Frequency of			Plane of Floor Uppermost Storey
		1Hz to 10Hz	10Hz to 50Hz	50Hz to 100Hz	All Frequencies
1	Buildings used for commercial purposes, industrial buildings and buildings of similar design	20	20 to 40	40 to 50	40
2	Dwellings and buildings of similar design and/or use	5	5 to 15	15 to 20	15
3	Structures that because of their particular sensitivity to vibration, do not correspond to those listed in Group 1 or 2 and have intrinsic value (eg buildings under a preservation order)	3	3 to 8	8 to 10	8

4.3 Construction Noise & Vibration Assessment

4.3.1 Demolition, Excavation & Construction Program and Equipment

At this early stage of the development, the full details of demolition, excavation and construction are unknown. Details on the duration of the works and proposed hours will be confirmed at a later date. It would be recommended that a site specific construction management plan be developed for the site when specific methods and program is known. However, an indication of plant equipment to be used during the work is provided in Table 13.

Table 13: Demolition, Excavation and Construction Equipment & Sound Power Levels, dB(A)

Plant Item	Plant Description	Maximum Sound Power Levels (re: 1pW)
Demolition		
1.	Excavator Mounted Hydraulic Breaker	115
2.	90lb Pneumatic Jack hammer	110
3.	Truck - Dump	110
4.	Power Generator	105
5.	20 tonne Excavator with Bucket	103
6.	30 tonne Excavator with Bucket	103
7.	5 tonne Excavator	102
8.	12 tonne Excavator	102
9.	5 tonne Bobcat	102
10.	Air Compressor - Silenced	93
Excavation		
11.	Excavator Mounted Hydraulic Breaker	115
12.	Rock Breaker	115
13.	90lb Pneumatic Jack hammer	110

Plant Item	Plant Description	Maximum Sound Power Levels (re: 1pW)
14.	30 tonne Excavator with Bucket	103
15.	Truck - Dump	110
16.	Piling Drilling Rig	117
17.	Concrete Saw	115
18.	Crane - Mobile	110
19.	Front End Loader	110
20.	Water Cart	107
Construction		
21.	90lb Pneumatic Jack hammer	110
22.	Cherry Picker	110
23.	Mobile Crane	110
24.	Truck – Cement Mixer	108
25.	Concrete Pump	106
26.	Concrete Vibrator	110
27.	Water Cart	107
28.	Crane - Diesel	106
29.	Air Compressor - Silenced	93

4.3.2 Noise Assessment

Whilst the specific methodology and number of plant and equipment have not defined at this stage of the project, based on the typical demolition and construction procedures and proximity of neighbouring premises, it is expected that the target levels may be exceeded during the peak demolition, excavation and construction activities. An indicative noise emission assessment of demolition activities is set out in Table 14.

Table 14: Predicted Demolition Noise Levels At Nearest Affected Receivers

Receiver Location	External Noise Assessment $L_{Aeq(15min)}$		Internal Noise Level $L_{Aeq(15min)}$	
	Predicted	Noise Targets	Predicted	Noise Targets
R1 - Four Seasons Hotel	72	70	N/A	N/A
R2 - Quay West	78	70	N/A	N/A
R3 - Marriott Hotel	77	70	N/A	N/A
R4 - 1 Alfred St	85	70	N/A	N/A
R5 - 19 Pitt St	93	70	N/A	N/A
C1 - 31A Pitt Street	93	70	68	50
C2 - 19-31 Pitt Street	93	70	68	50
C3 - 1 Alfred Street	85	70	60	50
C4 - 22 Pitt Street	87	70	62	50
C5 - Gateway, 1 Macquarie Place	77	70	52	50

Receiver Location	External Noise Assessment $L_{Aeq(15min)}$		Internal Noise Level $L_{Aeq(15min)}$	
	Predicted	Noise Targets	Predicted	Noise Targets
C6 - 37 Pitt Street	90	70	65	50
C7 - 6 Dalley Street	83	70	58	69
C8 - 210 George Street	82	70	35	50
C9 - Grosvenor Place, 225 George Street	76	70	43	50
C10 - 200 George Street (incomplete)	91	70	66	50

Notes: Bold numbers indicate exceedance of noise goal
 Predictions assume equipment located 5m within project boundary.
 Internal noise level assessment conservatively assumes 25dB(A) noise reduction through closed commercial building facade

Based on the indicative assessment, noise emission from peak demolition and excavation activities (particularly use of pneumatic breakers and hammers) is expected to exceed noise targets at nearest surrounding residential and commercial receiver locations. However this is not uncommon for works of this nature within the CBD, due to the close proximity of surrounding land uses.

Notwithstanding, due consideration should be given to the noise management measures outlined in Section 4.4 of this report in order to minimise noise impact. A detailed management plan should be developed for the works. In brief, the management of noise from construction activities relies heavily of consultation and communication with potentially affected locations.

4.3.3 Vibration Assessment

4.3.3.1 Vibration Sensitive Receivers

A list of the nearest vibration sensitive receivers to the site are summarised in Table 15.

Table 15: Nearest Vibration Receivers

Receiver ID	Description / Address	Approximate Distance to Project Boundary
C1	31A Pitt Street	3m
C2/R5	19-31 Pitt Street	3m
C3/R4	1 Alfred Street	15m
C4	22 Pitt Street	12m
C6	37 Pitt Street	7m
C7	6 Dalley Street	20m
C10	200 George Street (incomplete)	3m

4.3.3.2 Indicative Minimum Working Distances for Vibration Intensive Equipment

As a guide, indicative minimum working distances for typical items of vibration intensive plant and equipment are provided in Table 16. The minimum working distances are quoted for:

- cosmetic damage, based on the British Standard 7385; and
- human comfort, based on the DECC's 'Assessing Vibration; a technical guideline'.

Table 16: Recommended Minimum Working Distances for Vibration Intensive Equipment

Plant Item	Rating/ Description	Minimum Working Distance, m	
		Cosmetic Damage (BS 7385)	Human Response (DECC Guideline)
Vibratory Roller ²	<50 kN (Typically 1-2 tonnes)	5	15 - 20
	<100 kN (Typically 2-4 tonnes)	6	20
	<200 kN (Typically 4-6 tonnes)	12	40
	<300 kN (Typically 7-13 tonnes)	15	100
	>300 kN (Typically 13-18 tonnes)	20	100
	>300 kN (Typically >18 tonnes)	25	100
Compactor ¹	852G	10	20
Dozer ¹	(D810) with ripper	2 (nominal)	10
Excavator ¹	<=30 Tonne (travelling/ digging)	10	15
Grader ¹	<= 20 tonne	2 (nominal)	10
Small Hydraulic Hammer ²	300kg (5-12 tonne excavator)	2	7
Medium Hydraulic Hammer ²	900kg (12-18 tonne excavator)	7	23
Large Hydraulic Hammer ²	1600kg (18-34 tonne excavator)	22	73
Vibratory Pile Driver ²	Sheet Piles	2-20	20
Pile Boring ²	≤ 800 mm	2 (nominal)	N/A
Timber Pole Drill ¹	-	5	10
Jackhammer ²	Hand held	1 m (nominal)	Avoid contact with structure
Truck Movements ¹	-	-	10m

Notes: More stringent conditions may apply to heritage or other sensitive structures
The minimum working distances are indicative and will vary depending on the specific equipment and geotechnical conditions.
They apply to cosmetic damage of buildings and have been derived from measured vibration data from a range of projects available in our database under varying geotechnical conditions. Vibration monitoring should be undertaken to confirm the safe working distances at specific sites where considered necessary.

Based upon the distance of works to nearby receiver locations it is expected that vibration impacts will become more sensitive as the building is gradually demolished and the operation of pneumatic breakers comes closer to the ground level. As a result it is recommended that lower rated hydraulic hammers are used to demolish the base structure when works will need to occur within the nominated minimum working distances. Use of concrete saws or pulverisers may also be required to reduce potential damage to structures or minimise impacts onto adjacent tenancies. These distances would be confirmed through on site testing once works commence.

4.3.3.3 Potential for Vibration Impacts on Sensitive Items

In the event that the proposed residential premises at 1 Alfred Street and 19 Pitt Street approved under 1 Alfred Street DA 2010/2029 and 19 Pitt Street (Stage 1 consent only) DA 2010/1533, are occupied prior to completion of LLCQ, the residential locations are expected to be the nearest most sensitive receivers in regard to vibration impact during demolition and excavation. Residential premises however, may require adoption of varied management measures compared with nearby commercial premises, given their time of occupancy. The controls for managing potential structural damage would not alter under the potential future residential occupancy.

4.4 Construction Noise & Vibration Management

The most sensitive premises are expected to be the commercial premises located at 19-31 and 31A Pitt Street and 200 George Street together with proposed residential premises at 1 Alfred Street and 19 Pitt Street, in the event that these developments proceed through construction and occupation prior to demolition and excavation works associated with the Lend Lease Circular Quay redevelopment.

In regard to the CBD Rail Link (CBDRL) construction of the LLCQ, particularly any demolition and excavation would be expected to be completed prior to the CBD Rail Link project commencing. The proposed works are therefore not considered to impact upon the CBDRL during the construction phase.

Given the proximity and potential for noise impact upon nearby receivers, consideration to potential methods for noise reduction should be given during the development of the detailed demolition and construction plans.

Table 17 provides in-principle solutions to reduce construction noise and vibration impacts to sensitive receivers. Detailed mitigation and managed strategies would be developed once demolition and construction methodologies are known and would generally be outlined in detailed noise and vibration management plans. The advice provided here is in respect of acoustics only.

Table 17: Construction Noise and Vibration Management Options

Item	Description
Source controls	
Time constraints	Limit work to the approved standard hours. Consider implementing respite periods with low noise/vibration-producing construction activities.
Scheduling	Perform noisy work during less sensitive time periods.
Equipment restrictions	Select low-noise plant and equipment. Ensure equipment has quality mufflers installed.
Emission restrictions	Establish stringent noise emission limits for specified plant and equipment. Implement noise monitoring audit program to ensure equipment remains within specified limits.
Substitute methods	Use quieter and less vibration emitting construction methods where possible. For example, if piling is required, bored piles rather than impact-driven piles will minimise noise and vibration impacts. Similarly, diaphragm wall construction techniques, in lieu of sheet piling, will have significant noise and vibration reduction benefits.

Item	Description
Limit equipment on site	Only have necessary equipment on site.
Limit activity duration	Where possible, concentrate noisy activities at one location and move to another as quickly as possible. Any equipment not in use for extended periods during construction work should be switched off.
Equipment Location	Noisy plant and equipment should be located as far as possible from noise sensitive areas, optimising attenuation effects from topography, natural and purpose built barriers and materials stockpiles.
Site access	Vehicle movements outside construction hours, including loading and unloading operations, should be minimised and avoided where possible.
Equipment maintenance	Ensure equipment is well maintained and fitted with adequately maintained silencers which meet the design specifications.
Reduced equipment power	Use only necessary size and power.
Quieter work practices	For example, implement worksite induction training, educating staff on noise sensitive issues and the need to make as little noise as possible.
Reversing alarms	Consider alternatives, such as manually adjustable or ambient noise sensitive types ("smart" reversing alarms) and closed circuit TV systems. Alternative site management strategies can be developed, in accordance with the Occupational Health and Safety Plan, with the concurrence of the Occupational Health and Safety Officer.
Path controls	
Noise barriers	Consider installing temporary construction noise barriers. Locate equipment to take advantage of the noise barriers provided by existing site features and structures.
Project Planning	Construction should be programmed so that noise barriers or mounding required to control noise are built as soon as possible.
Enclosures	Install noise-control kits for noisy mobile equipment and shrouds around stationary plant, as necessary.
Increased distance	Locate noisy plant as far away from noise-sensitive receptors as possible.
Receptor controls	
Consultation	Community consultation, information, participation and complaint responses are essential aspects of all construction noise management programs. They typically involve: <ul style="list-style-type: none"> • A community information program before construction and/or high risk activities is commenced. This usually involves a leaflet distribution and direct discussions and negotiations with affected residents, explaining the type, time and duration of expected noise emissions. • The involvement of affected residents in the development of acceptable noise management strategies. • A nominated community liaison officer with a contact telephone number. • A complaints hotline. • Timely responses to complaints, providing information on planned actions and progress towards the resolution of concerns.

Item	Description
Noise / Vibration Monitoring	<ul style="list-style-type: none"> • Noise and vibration monitoring for all major equipment and activities on site should be undertaken in order to evaluate site work and identify the highest noise and vibration generating activities and establish any methods of amelioration. • Attended monitoring of demolition noise levels can be undertaken where appropriate in response to a noise related complaint(s) (determined on a case-by-case basis). • Attended vibration measurements are recommended at the commencement of vibration generating activities to confirm that vibration levels are within the acceptable range to prevent building damage. • Where attended vibration monitoring is not feasible, due to extended periods of vibration intensive works, a permanent vibration monitoring system is to be installed to warn plant operators (via flashing light, audible alarm, etc.) that there is potential cosmetic damage to buildings and structures. • For plant and equipment that is identified as the source of complaint, it is recommended that noise level testing of equipment be undertaken so as to confirm the sound power level of the equipment. The measured sound power level can be compared with the noise levels in Table 13. • Noise emission from individual plant items is not anticipated to vary significantly over a period of less than 6 months. Plant and equipment operating on the site for more than 6 months should be re-tested to confirm that noise levels from individual plant items are still within the acceptable noise range, or where it is clearly evident that either plant or equipment may be exceeding the maximum levels identified in Table 13.

5 Operational Noise

5.1 Noise Criteria

The proposed development may include various commercial and retail use occupancies. This may include liquor licensed venues, cafes, restaurants and retail shops. While, at this stage the specific uses of occupancies have not been determined, it could be expected that some will seek operating hours comparable to existing uses at Jacksons on George (24/7) and the Rugby Club. These uses would be subject to detailed design at a later stage of the development.

The development proposes to retain Jacksons on George and the Rugby Club. Noise sensitive uses proposed in proximity to the uses, particularly Jacksons on George with 7 day 24 hour licencing, will need to be addressed at any new noise sensitive receptors surrounding the site.

In regard to noise management of new development, current noise policy places the onus of noise control on the noise generator, and therefore any commercial or retail occupancy would need to give consideration to potential impact upon any existing and future residential premises.

Jacksons on George and the Rugby Club would however need to operate in accordance with existing operating approvals. Any future noise sensitive development built in proximity to these developments would need to have due regard to their current operational noise emission. The uses proposed for LLCQ do not include any development that is considered more sensitive to the operation of these sites. This should however be reviewed during the design development stage.

Any future commercial or retail occupancies would need to be designed to comply with the relevant acoustic requirements and criteria set by the consent authority. The City of Sydney have Standard Conditions of Development Consent that relate to noise emission from various sources, including mechanical equipment, and patron and music noise associated with retail and hospitality premises. In addition, where premises are licensed, the Office of Liquor Gaming and Racing (OLGR) have standard noise criteria; however are generally consistent with the Council's Standard Conditions.

Noise criteria for operational noise from the site are established from the existing background noise levels at nearest sensitive receptor locations. Table 18 sets out long term ambient noise monitoring from which noise criteria could be established. Noise criteria for licensed premises are typically assessed in octave-bands whilst noise from mechanical equipment is assessed against the broad band noise levels. Monitoring relevant to specific assessment locations may be warranted.

Table 18: Measured L₉₀ Background Noise Levels

Time	Overall dB(A)	Octave Band Centre Frequency – Hz (dBZ)								
		31.5	63	125	250	500	1k	2k	4k	8k
7am – 6pm	60	64	64	63	61	58	55	50	43	32
6pm – 10pm	57	62	61	59	56	54	52	47	41	31
10pm – 7am	55	60	60	58	56	52	49	46	41	31

Time	Overall dB(A)	Octave Band Centre Frequency – Hz (dBZ)								
		31.5	63	125	250	500	1k	2k	4k	8k
10pm – 12am	56	61	61	58	56	53	50	46	41	31
12am – 7am	50	55	55	53	51	47	44	41	36	26

5.2 Review and Recommendations

Noise emission from the commercial office tower building would generally be limited to mechanical plant and equipment. It is expected that equipment plant rooms will be situated over three levels of the commercial office tower (lower level near ground, mid-level and rooftop). The attenuation of noise generated by modern commercial office plant and equipment to levels appropriate for adjacent receivers including existing commercial office (and if relevant, future residential occupants at 1 Alfred and 19 Pitt Streets) is industry standard practice and can be addressed by what are proven industry standard design and construction techniques.

It is also worth considering that adjacent redevelopments at 200 George Street (commercial office under construction) and as contemplated at 1 Alfred and 19 Pitt streets (approved as modern CBD residential living) are all likely to incorporate internal air conditioned environments with heavily engineered facades that will further attenuate noise emission impacts from LLCQ.

At this stage of the development, the specific mechanical equipment has yet to be determined to allow specific acoustic assessment, and therefore the following in-principle noise management measures and approach for acoustic assessment is provided:

- Acoustic assessment of mechanical services equipment will need to be undertaken during the detail design phase of the development to ensure that they shall not either singularly or in total emit noise levels which exceed relevant conditions
- As noise control treatment can affect the performance of the mechanical services system, it is recommend that consultation with an acoustic consultant be made during the initial phase of mechanical services system design in order to reduce the need for revision of mechanical plant and noise control treatment
- Mechanical plant noise emission can be controlled by appropriate mechanical system design and implementation of common engineering methods that may include:
 - procurement of 'quiet' plant
 - strategic positioning of plant and plant room air-intakes and discharges, away from sensitive neighbouring premises, maximising the intervening shielding between the plant and sensitive neighbouring premises
 - commercially available silencers or acoustic attenuators for air discharge and air intakes of plant
 - acoustically lined and lagged ductwork
 - acoustic screens/barriers between plant and sensitive neighbouring premises, or

- partially-enclosed or fully-enclosed acoustic enclosures over plant.
- Equipment shall be mounted on vibration isolators and balanced in accordance with Australian Standard 2625 '*Rotating and Reciprocating Machinery – Mechanical Vibration*'.

Operational noise from potential retail or hospitality uses also needs to be considered, and can include aspects such as patron and music noise. The control of noise from such premises is best achieved at the source; however as details of the specific occupancies are yet to be determined, detailed acoustic assessment cannot be undertaken.

The attenuation of noise generated by modern retail or hospitality related plant and equipment to levels appropriate for adjacent receivers including existing commercial office (and if relevant, future residential occupants at 1 Alfred and 19 Pitt Streets) is industry standard practice and can be addressed by a what are proven industry standard design and construction techniques

6 Noise and Vibration Intrusion

6.1 General Noise Intrusion Criteria

Noise intrusion from the existing environment onto the proposed development should be considered and assessed during the specific design of the building. Typical noise sources in the existing environment include road traffic and mechanical plant and equipment from adjacent buildings. Noise assessment and internal design of the development for these aspects is not usually the subject of consent authority conditions and would be largely determined by client amenity requirements or certification such as Green Star ratings.

Table 19 presents the '*Recommended Design Sound Levels for Different Areas of Occupancy in Buildings*' as specified in Table 1 of Australian Standard AS2107, also referenced in Green Star rating requirements, can be adopted for the design of noise intrusion.

Table 19: Recommended Design Sound Levels for Different Areas of Occupancy in Buildings

Type of occupancy/ activity	Recommended design sound level, L_{Aeq} dB(A)		Recommended reverberation time (T),s
	Satisfactory	Maximum	
Office Buildings			
Board and conferences rooms	30	40	0.6 to 0.8
Cafeterias	45	50	See Note 3
Call centres	40	45	0.1 to 0.4
Computer rooms	45	50	See Note 3
Corridors and lobbies	45	50	0.4 to 0.6
Design offices	40	45	0.4 to 0.6
Draughting offices	40	50	0.4 to 0.6
General office areas	40	45	0.4 to 0.6
Private offices	35	40	0.6 to 0.8
Public spaces	40	50	0.5 to 1.0
Reception areas	40	45	See Note 3
Rest rooms and tea rooms	40	45	0.4 to 0.6
Toilets	50	55	-
Undercover carparks	55	65	-
PUBLIC BUILDINGS			
Restaurants and cafeterias -			
Cafeterias and food courts	45	55	See Note 3
Coffee bars	45	50	<1.0
Restaurants	45	50	<1.0

Notes: Reference should be made to AS2017-2000 in regard to specific notes or clarification of the recommended noise levels and reverberation times.

6.2 Rail Noise and Vibration Criteria

As the LLCQ development is in proximity to the CBD Rail Link (CBDRL) alignment TfNSW have requested that the proposal be reviewed in accordance with the SEPP (Infrastructure) 2007 ('ISEPP'). The ISEPP sets out the following clauses pertinent to noise and vibration assessment of the LLCQ proposal:

Clause 87 of ISEPP 2007 requires as follows:

87 Impact of rail noise or vibration on non-rail development

1. This clause applies to development for any of the following purposes that is on land in or adjacent to a rail corridor and that the consent authority considers is likely to be adversely affected by rail noise or vibration:
 - a. *a building for residential use,*
 - b. *a place of public worship,*
 - c. *a hospital,*
 - d. *an educational establishment or child care centre.*
2. *Before determining a development application for development to which this clause applies, the consent authority must take into consideration any guidelines that are issued by the Director-General for the purposes of this clause and published in the Gazette.*
3. *If the development is for the purposes of a building for residential use, the consent authority must not grant consent to the development unless it is satisfied that appropriate measures will be taken to ensure that the following LAeq levels are not exceeded:*
 - a. *in any bedroom in the building - 35 dB(A) at any time between 10 pm and 7am,*
 - b. *anywhere else in the building (other than a garage, kitchen, bathroom or hallway) - 40 dB(A) at any time.*

88A Major development within Interim Metro Corridor

1. *This clause applies to land within the City of Sydney that is within the Interim Metro Corridor.*

...3 A consent authority must not grant consent to major development on land to which this clause applies if the development would have an adverse affect on the viability of the proposed metro, including by increasing the likely cost of developing the proposed metro.

In accordance with Clause 87 of the ISEPP, acoustic assessment of a commercial building is not specifically required. Notwithstanding, further discussion regarding noise and vibration from the CBDRL is outlined in the following section.

6.3 Review and Recommendations

6.3.1 Ambient Noise Intrusion

In regard to the primary office tower, the highest external ambient noise would be related to road traffic along the Pitt St façade as the development is set back from George St. The CBDRL is not relevant to airborne noise intrusion, as it will be underground.

From the noise monitoring, location S7 and S8 are most relevant in regard to ambient traffic noise levels. The highest L_{Aeq} noise levels recorded at the locations are reproduced in Table 20. Lower noise levels would be expected at upper levels of the office tower.

Table 20: Short-Term Noise Measurement Results for Noise Intrusion Assessment

Date / Time	Descriptor	Overall dB(A)	Octave Band Centre Frequency – Hz (dBZ)								
			31.5	63	125	250	500	1k	2k	4k	8k
Location S7 - 30 Pitt Street											
Saturday 14/4/2012 11:12-11:27	L_{eq}	71	74	79	69	65	65	67	65	53	46
	L_{90}	62	69	67	64	61	59	57	52	44	32
Location S8 - 37 Pitt St (external)											
Friday 18/10/2013 14:38-14:48	L_{eq}	68	73	74	70	67	66	64	60	54	46
	L_{90}	63	70	67	66	62	61	58	53	46	35

At this stage of the development, the design and construction of the building, including the specific uses at the internal perimeter of the façade, is yet to be determined. However for new office buildings the thermal performance requirement of the façade typically establishes a sufficient acoustic performance for noise intrusion. Thermal and shading design for commercial buildings can involve use of double and triple glazed façade systems which could be appropriately designed to meet internal acoustic requirements.

The attenuation of external noise generated from external sources to levels acceptable to occupants is industry standard practice and can be addressed by what are proven industry standard design and construction techniques

Determination of internal acoustic criteria and acoustic design of the façade system would form part of the design development requirements of the project.

6.3.2 CBD Rail Link (CBDRL)

The proposed development is consistent with the existing surrounding land use in the locality being predominately commercial office and retail. The LLCQ development does not propose an amendment of land use to a more sensitive receptor such as residential as is the case at adjacent sites at 1 Alfred Street and 19 Pitt Street.

The CBDRL is in closer proximity to the existing Marriott Hotel, which would otherwise determine the noise and vibration mitigation design for the CBDRL in the locality.

The introduction of basement levels in LLCQ, in closer proximity to the CBDRL will also not result in an increase in vibration and structure radiated noise at occupied levels above ground.

Notwithstanding, preliminary assessment is that noise and vibration from the CBDRL would have a low risk of impacting the commercial development at LLCQ given the distance to the CBDRL alignment and that LLCQ is adjacent a proposed station location (Macquarie Place) where trains would be travelling slowly.

LLCQ has been assessed not to adversely affect the viability of the proposed metro, by otherwise increasing the likely cost of developing the proposed metro. LLCQ therefore satisfies the requirements of Clause 88 of the ISEPP,

7 Conclusion

Renzo Tonin & Associates has completed an assessment of noise and vibration in relation to the Planning Proposal (PP) submission to be lodged with the City of Sydney for the Lend Lease Circular Quay (LLCQ) project.

At this PP stage, there is insufficient detail to carry out a detailed acoustic assessment of the proposed development; however, this report has outlined the primary acoustic considerations for the development, including:

- Relevant noise and vibration criteria applicable to the development
- Identification of noise and vibration sensitive development surrounding the site
- Existing ambient and background noise levels at sensitive receptor locations
- Establishment of project noise goals
- Potential noise and vibration impacts from construction and operation of the development
- Potential noise impacts from the existing or future environment on the development
- Methods by which noise and vibration can be managed and mitigated in accordance with the relevant policies and guidelines

Further to the above, we advise the following:

- Noise and vibration impacts from demolition, excavation and construction activities are likely to exceed external noise goals and the management measures and procedures have been outlined for incorporation into a site specific management plan.
- Potential noise impacts from future commercial and retail occupancies can be managed and controlled following further acoustic assessment once detail of the future commercial and retail occupancies have been determined.
- Potential noise intrusion impacts from the existing or future environment on the development can be controlled and managed with further acoustic assessment at the design stage.
- Noise and vibration from the CBDRL should not affect LLCQ, and the proposal was deemed not to adversely affect the viability of the proposed CBDRL.

Noise and vibration issues identified and forecast to arise from the LLCQ development are common aspects associated with commercial development in the CBD and can be addressed by what are proven industry standard design and construction techniques.

APPENDIX A Glossary of Terminology

The following is a brief description of the technical terms used to describe noise to assist in understanding the technical issues presented.

Adverse Weather	Weather effects that enhance noise (that is, wind and temperature inversions) that occur at a site for a significant period of time (that is, wind occurring more than 30% of the time in any assessment period in any season and/or temperature inversions occurring more than 30% of the nights in winter).
Ambient Noise	The all-encompassing noise associated within a given environment at a given time, usually composed of sound from all sources near and far.
Assessment Period	The period in a day over which assessments are made.
Assessment Point	A point at which noise measurements are taken or estimated. A point at which noise measurements are taken or estimated.
Background Noise	Background noise is the term used to describe the underlying level of noise present in the ambient noise, measured in the absence of the noise under investigation, when extraneous noise is removed. It is described as the average of the minimum noise levels measured on a sound level meter and is measured statistically as the A-weighted noise level exceeded for ninety percent of a sample period. This is represented as the L90 noise level (see also Rating Background Level 'RBL').
CNVMP	(Abbr.) Construction Noise and Vibration Management Plan
Decibel [dB]	The units that sound is measured in. The following are examples of the decibel readings of every day sounds: 0dB The faintest sound we can hear 30dB A quiet library or in a quiet location in the country 45dB Typical office space. Ambience in the city at night 60dB CBD mall at lunch time 70dB The sound of a car passing on the street 80dB Loud music played at home 90dB The sound of a truck passing on the street 100dB The sound of a rock band 115dB Limit of sound permitted in industry 120dB Deafening
dB(A):	A-weighted decibels. The ear is not as effective in hearing low frequency sounds as it is hearing high frequency sounds. That is, low frequency sounds of the same dB level are not heard as loud as high frequency sounds. The sound level meter replicates the human response of the ear by using an electronic filter which is called the "A" filter. A sound level measured with this filter switched on is denoted as dB(A). Practically all noise is measured using the A filter.
Frequency	Frequency is synonymous to pitch. Sounds have a pitch which is peculiar to the nature of the sound generator. For example, the sound of a tiny bell has a high pitch and the sound of a bass drum has a low pitch. Frequency or pitch can be measured on a scale in units of Hertz or Hz.
ICNG	(Abbr.) Interim Construction Noise Guideline, published by the NSW Department of Environment and Climate, 1997
Impulsive noise	Having a high peak of short duration or a sequence of such peaks. A sequence of impulses in rapid succession is termed repetitive impulsive noise.
INP	(Abbr.) Industrial Noise Policy, published by the NSW Department of Environment and Climate, 1990
Intermittent noise	The level suddenly drops to that of the background noise several times during the period of observation. The time during which the noise remains at levels different from that of the ambient is one second or more.
Lmax	The maximum sound pressure level measured over a given period.

Lmin	The minimum sound pressure level measured over a given period.
L1	The sound pressure level that is exceeded for 1% of the time for which the given sound is measured.
L10	The sound pressure level that is exceeded for 10% of the time for which the given sound is measured.
L90	The level of noise exceeded for 90% of the time. The bottom 10% of the sample is the L90 noise level expressed in units of dB(A).
Leq	The "equivalent noise level" is the summation of noise events and integrated over a selected period of time.
Reflection	Sound wave changed in direction of propagation due to a solid object obscuring its path.
SEL	(Abbr.) Sound Exposure Level is the constant sound level which, if maintained for a period of 1 second would have the same acoustic energy as the measured noise event. SEL noise measurements are useful as they can be converted to obtain Leq sound levels over any period of time and can be used for predicting noise at various locations.
Sound	A fluctuation of air pressure which is propagated as a wave through air.
Sound Absorption	The ability of a material to absorb sound energy through its conversion into thermal energy.
Sound Level Meter	An instrument consisting of a microphone, amplifier and indicating device, having a declared performance and designed to measure sound pressure levels.
Sound Pressure Level	The level of noise, usually expressed in decibels, as measured by a standard sound level meter with a microphone.
Sound Power Level	Ten times the logarithm to the base 10 of the ratio of the sound power of the source to the reference sound power.
Tonal noise	Containing a prominent frequency and characterised by a definite pitch.